

MOTOR (Motore)	CLASS "B" - SLEEVE BEARINGS MANUFACTURED (Classe "B" - Esecuzione a Bronzine)
HOUSING (Coclea)	GALVANIZED SHEET IRON (Lamiere Zincate)
FAN DECK SUPPORT (Supporto Gruppo Ventilante)	GALVANIZED SHEET IRON (Lamiere zincate)
BLOWERS No.2 Ø200 x 240 (Ventole N°2 Ø200 x 240)	ALUMINIUM (Alluminio con Mozzo in Acciaio)
ELECTRICAL SPECIFICATION No. (Controllo elettrico Prescrizione)	G.2212/1A



FAN-DECK BALANCING IN ACCORDANCE EL.UN.0082 (grado equilibratura) **6.3**

CODE: 4-017-1483  
 TYPE: 3FGB-CO 345-70-4V/1  
 230/240V ~ 50Hz 3,5Amax.  
 730Win-max 1210Rpm TH.PROT  
 INS.CL.B C=8µF 450VL  
 MOT. : 4-010-2064/50  
 COD. : 3071233 DATA **CE**

BLUE	COMMON
BROWN	S-MAX VEL.
VIOLET	MAX VEL.
ORANGE	MED VEL.
RED	MIN VEL.
YELLOW	C
GREEN	
YELLOW/GREEN	

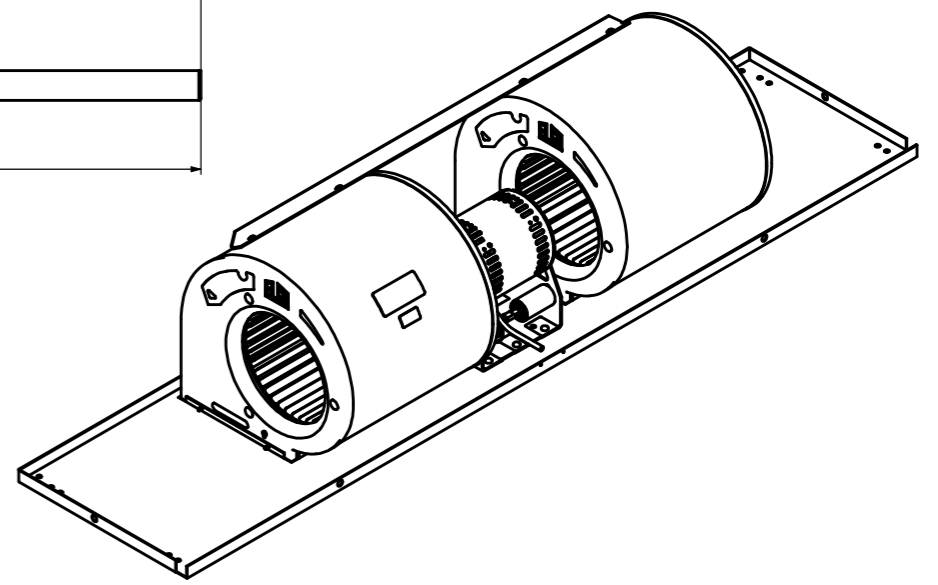

- 1) TO TIGHTEN THE HOUSING FIXING SCREWS ON THE PLATE WITH TORQUE 15-17 Kgcm (Serrare le viti di fissaggio coclea con una coppia di 15-17 Kgcm)
- 2) BLOWER MUST BE CENTERED IN TO THE HOUSING (Controllare la scentratura assiale della ventola, massimo consentito 2mm)
- 3) TO LOCK BLOWER GRUB SCREWS IN ACCORDANCE EL.UN.0075 (Bloccare i grani di fissaggio delle ventole secondo normativa EL.UN.0075)
- 4) MOTOR FIXING CLAMP IN ACCORDANCE EL.UN.0076 (Fissare le fascette di bloccaggio motore secondo normativa EL.UN.0076)

Rev	Date	Description	Executed	Checked
D	28-02-2012	SOSTITUITO COCLEE, AGGIORNATO DIMENSIONI BOCHE BACINELLA	Mod. 12/0027 A.T.	Pedrini R. Sirtori
C	31-08-2010	ALLARGATO COCLEE DI 4mm ( DA 289 A 293 ), ALLARGATO DI CONSEGUENZA LE BOCHE BACINELLA	Mod. 10/0085 A.T.	Pedrini R. Sirtori
B	30-10-2009	SOSTITUITO SUPPORTO LARGHEZZA 75 CON SUPPORTO LARGHEZZA 130		Pedrini R. Sirtori
A	22-02-2006	VARIATO INDICAZIONE VELOCITA' IN TARGHETTA ( ERANO INDICATE CON 1-2-3-4 )		Pedrini R. Sirtori

For dimension without tolerance see standard UNI EN 22768-mK		Treatment	A2
Material		Weight gr.	Release
Drawn Pedrini R.	Date 07-12-2005	GR. VENT. 230/240V 50Hz	D
Check T. Sirtori	Scale	TYPE : 3FGB-CO-345-70-4V/1	
SABIANA MAESTRO 4 COD : 3071233		4-017-1483	

MODIFICATIONS

DRAWING MADE BY CAD HAND MADE MODIFICATIONS ARE FORBIDDEN

THIS DRAWING IS OUR PROPERTY. ANY PARTIAL OR COMPLETE COPY IS FORBIDDEN WITHOUT PREVIOUS WRITTEN AUTHORISATION